



CATALOGUE
HYDRAULIC TIPPING SOLUTIONS



HYVA WETKITS

We offer a wide variety of hydraulic systems which can cope with the most demanding work conditions and applications.

Every Hyva customer can count on being fully served – from specifying the wetkit for a given application to installation on the vehicle. Our wetkits are individually specified by experienced Hyva staff with years of market experience in matching Hyva cylinders to assure best possible performance.

Wetkit for tipping semitrailers **page 4-5**

Wetkit for tipper truck **page 6-7**

Wetkit for moving floor, gas and liquid semitrailers **page 8-9**

Wetkit for moving floor and tipping semitrailers **page 10-11**

Wetkit for gas and liquid semitrailers with oil cooler **page 12-13**

Hyva Alpha front end cylinders **page 14-15**

Underbody cylinders and power pack wetkits **page 16-19**

Power take offs (PTO) **page 20-21**

Pumps **page 22-25**

Tipping valves HT1150 series **page 26-27**

Tipping valves HT1220 series **page 28-29**

Other valves **page 30**

Oil tanks **page 31-33**

Air controls **page 34-35**

High and low pressure hoses **page 36**

Couplings and seals **page 37**

High and low pressure adaptors **page 38-39**

Interesting examples of installations **page 40-41**

WETKITS FOR TIPPING SEMITRAILERS

Optimal efficiency, low weight, short tipping cycle and safety are key principles followed while configuring wetkits for our customers. Our systems are fully optimized in terms of oil capacity, flow and working pressure to ensure the highest level of efficiency and safety.

A wide range of gear and piston pump sizes allows us to select a wetkit with highest performance for every type of truck, gearbox and PTO.

Hyva offers a complete range of oil tanks manufactured from highest quality steel and aluminium in several mounting positions on the truck frame or behind the cabin. The design ensures optimized shape and superior size to volume ratio to utilize as little space as possible, following the latest trends on modern trucks.

Hyva HT tipping valves are specially designed for tipping applications. They guarantee the highest standard of efficiency and safety. High flow rates reduce the tipping cycle, wear on the pump and extend the overall lifetime of the system. For over 15 years this unique design concept has proven to be the safest solution for tipping applications in all possible working conditions around the world.

Hyva tipping systems based on such components, and in combination with Hyva Alpha cylinders, are a fully harmonized and highly efficient solution, bringing its owner real savings at safe working conditions.



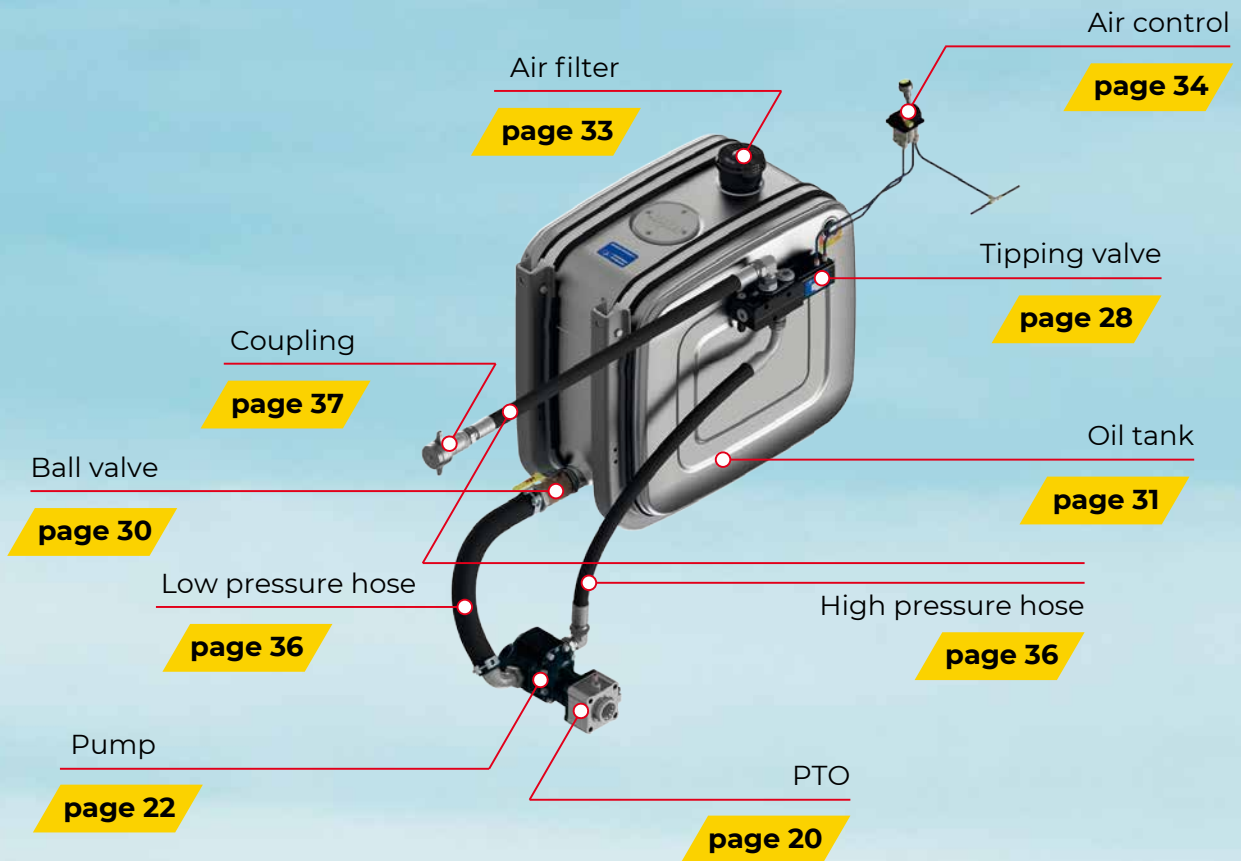

WETKITS FOR TIPPER TRUCKS

In the case of tipper trucks, the key features of Hyva wetkits become even more relevant as the expectation for efficiency and productivity is very high.

Hyva systems meet these demands and ensure shortest tipping cycle times at low weight, together with safe and breakdown free operation.

With full integration of the hydraulic system and tipping cylinder, we are able to deliver maximum performance. A wide range of gear and piston pump sizes allows us to reach the highest possible oil flow for every type of truck, gearbox and PTO. And a full range of oil tanks allows optimal size and oil volume at low weight.

Hyva HT tipping valves are specially designed for tipping applications. In combination with a knock off valve they guarantee the highest standard of efficiency and safety. High flow rates reduce the tipping cycle, wear on the pump and extend the overall lifetime of the system. For over 15 years this unique design concept has proven to be the safest solution for tipping applications in all possible mining and construction working conditions around the world.



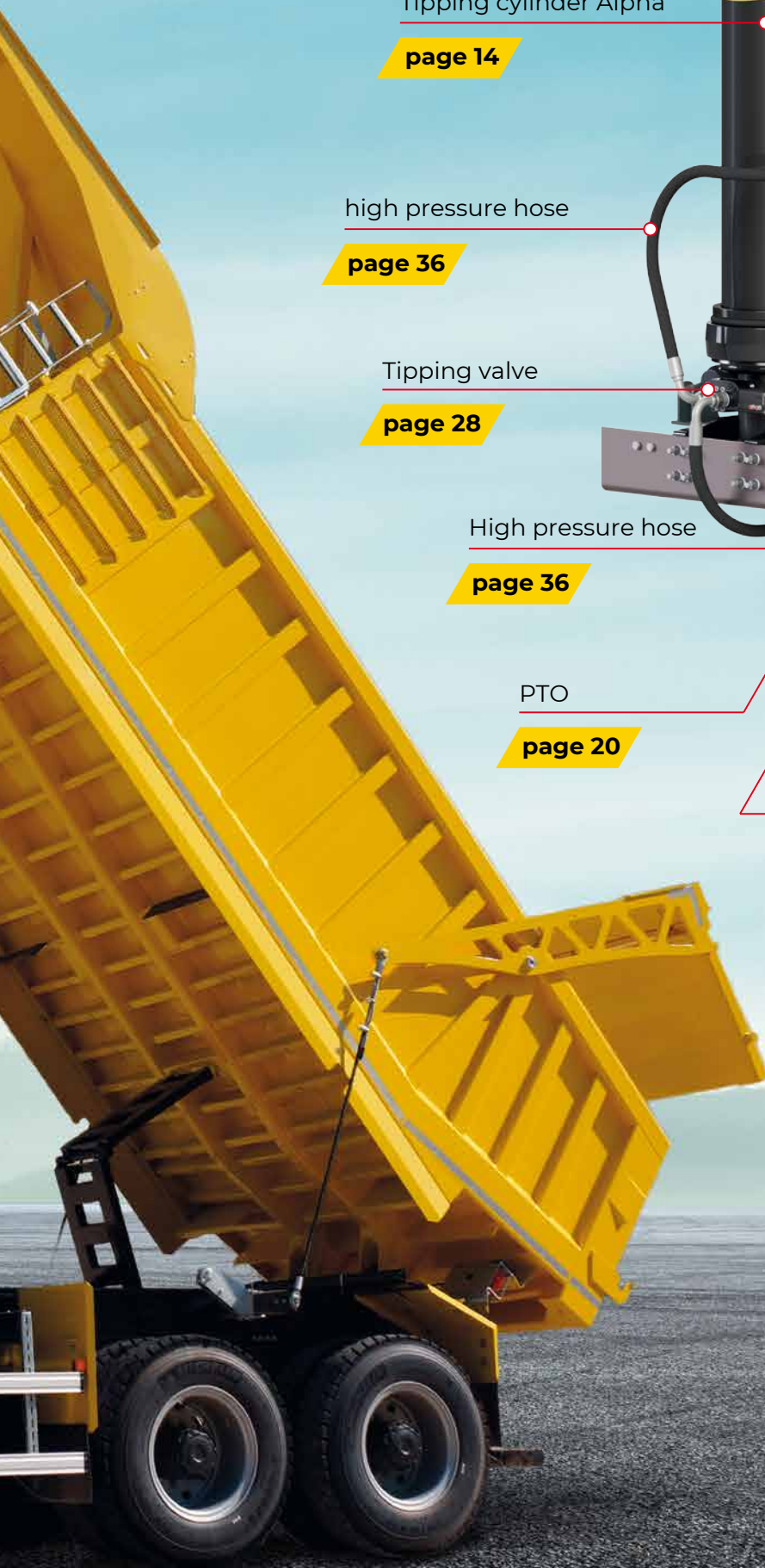

Tipping cylinder Alpha

page 14

high pressure hose

page 36

Tipping valve

page 28

High pressure hose

page 36

PTO

page 20

Knock off valve

page 30

Return filter

page 33

Air filter

page 33

Oil tank

page 31

Ball valve

page 30

Low pressure hose

page 36

Pump

page 22

WETKITS FOR MOVING FLOOR, GAS AND LIQUID SEMITRAILERS

These 2-line wetkits are intended for applications such as:

- Moving floor systems
- Low bed trailers with hydraulic ramps and adjustments
- Cranes, hookloaders, skiploaders and similar
- Unloading gas and liquid tankers

Such applications demand some specific requirements such as low weight, high working pressure for longer periods of unloading, and, compact dimensions which contribute to the overall productivity of the vehicle. Hyva components used in such wetkits are designed to meet these requirements. We offer several proven solutions such as hose guides, various options for coupling locations, low return filters and other solutions useful for such applications. A wide range of gear and piston pump sizes allows us to reach the highest possible oil flow for every type of truck, gearbox and PTO. A full range of aluminium and steel oil tanks allows optimal size and oil volume at low weight.



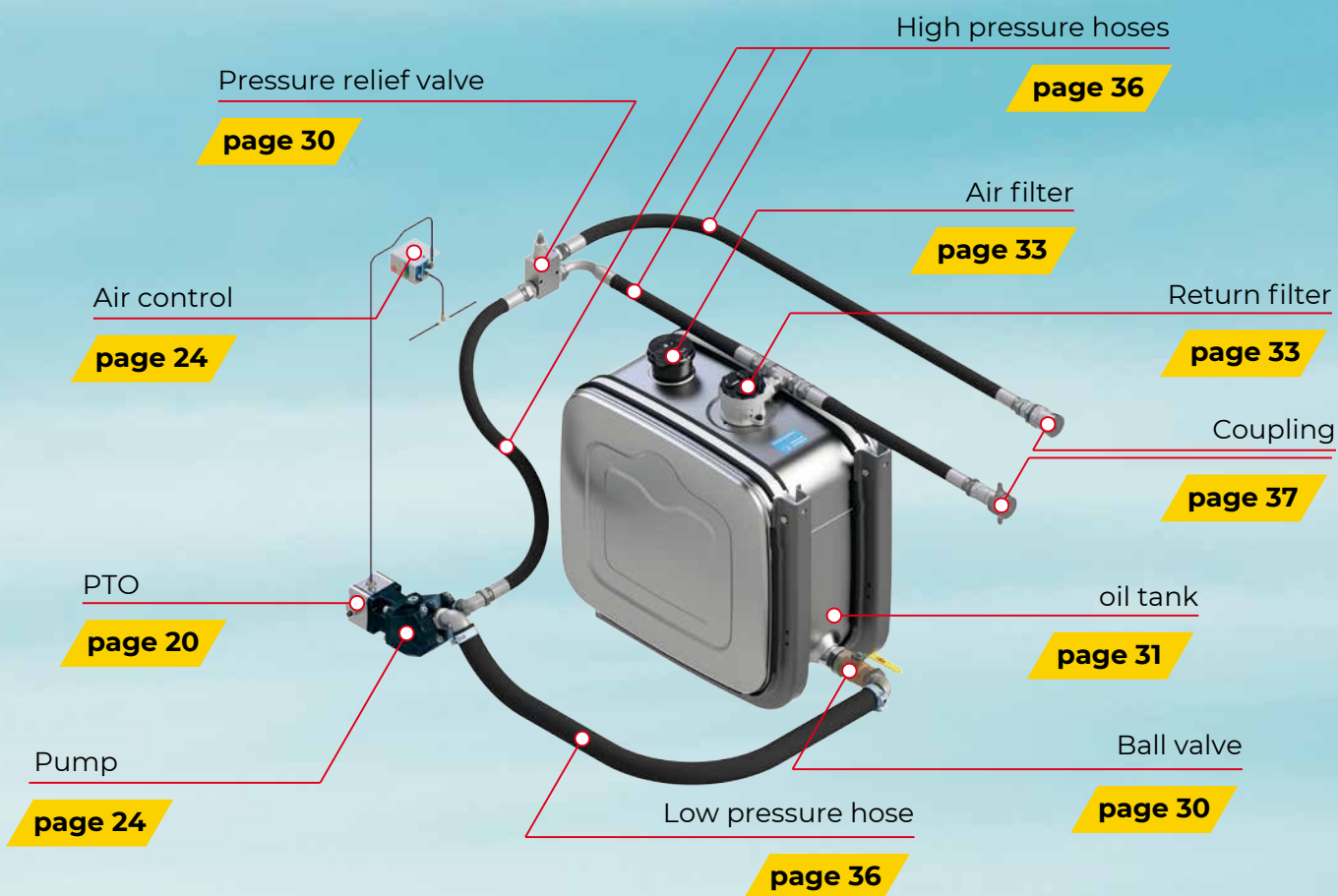

WETKIT FOR MOVING FLOOR AND TIPPING SEMITRAILERS

This solution is suggested to customers who use their tractors with tipping and moving floor, liquid tanker semitrailers or other configurations where a 2-line hydraulic system is needed.

The working pressure on the Hyva dual pressure valve can be changed easily and safely. We can select one of several pressure combinations, the most common is 170/250 bar.

These wetkits are universal and allow interchangeability of the tractor with several semitrailers in the customer's fleet.



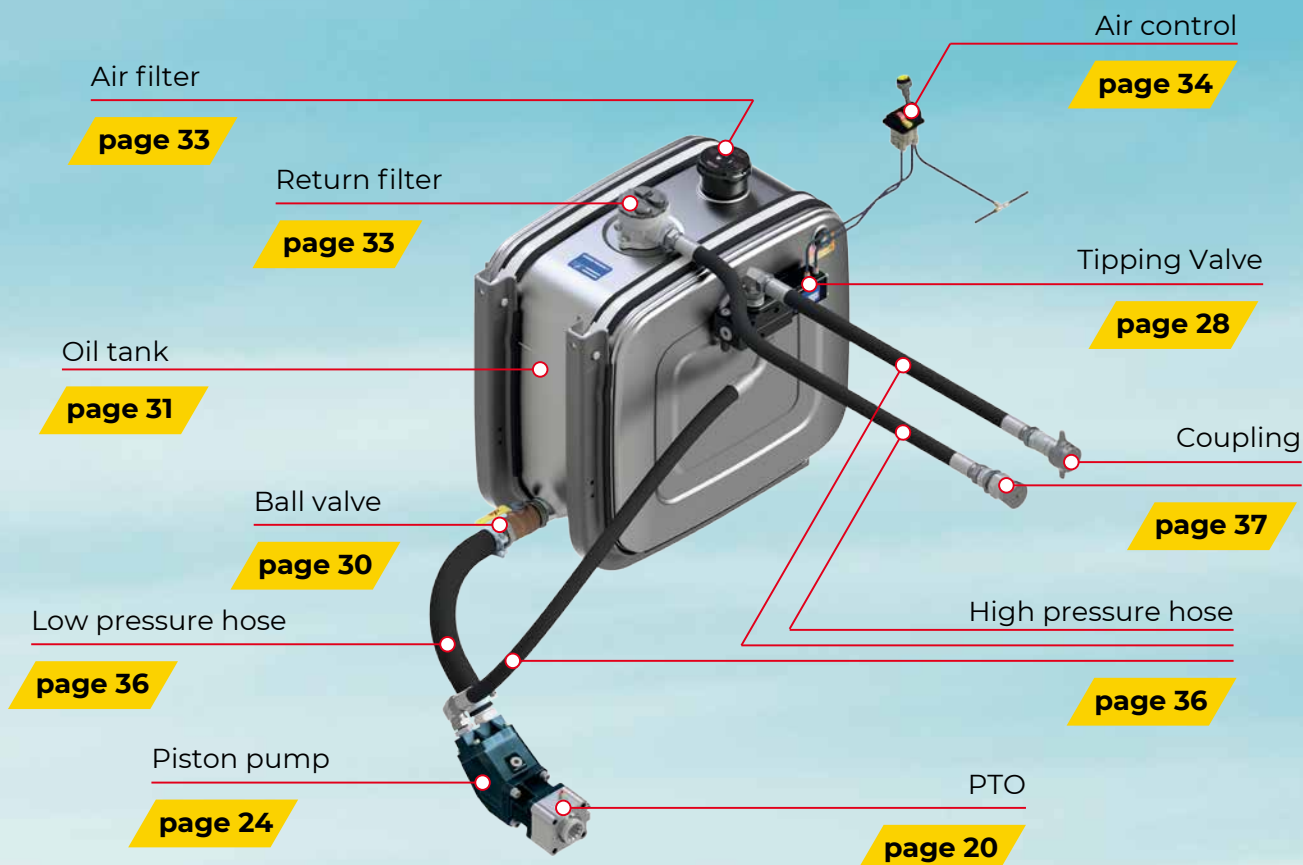

WETKITS FOR GAS AND LIQUID SEMITRAILERS WITH OIL COOLER

This solution is highly recommended for applications where the hydraulic system is required to work for long periods of time with high pressure which can cause significant oil heating. This compact solution with integrated oil cooler is a great choice to work with hydraulic motors driving, for example, gas or liquid unloading systems or moving floor and other systems where long operation at controlled operation is needed. The cooling system is hydraulically driven and this solution is ADR standard suitable.

Its compact and efficient design requires only a very small amount of oil. Its tank contains just under 20 litres, while a traditional hydraulic wetkit without cooling needs 170 litres of oil or more. The weight difference between these solutions can reach 200kg which is critical for efficiency in modern transportation, especially for gas and liquid.

The system is made of stainless steel to cope with hard working conditions and frequent washing of trucks transporting chemical liquids.



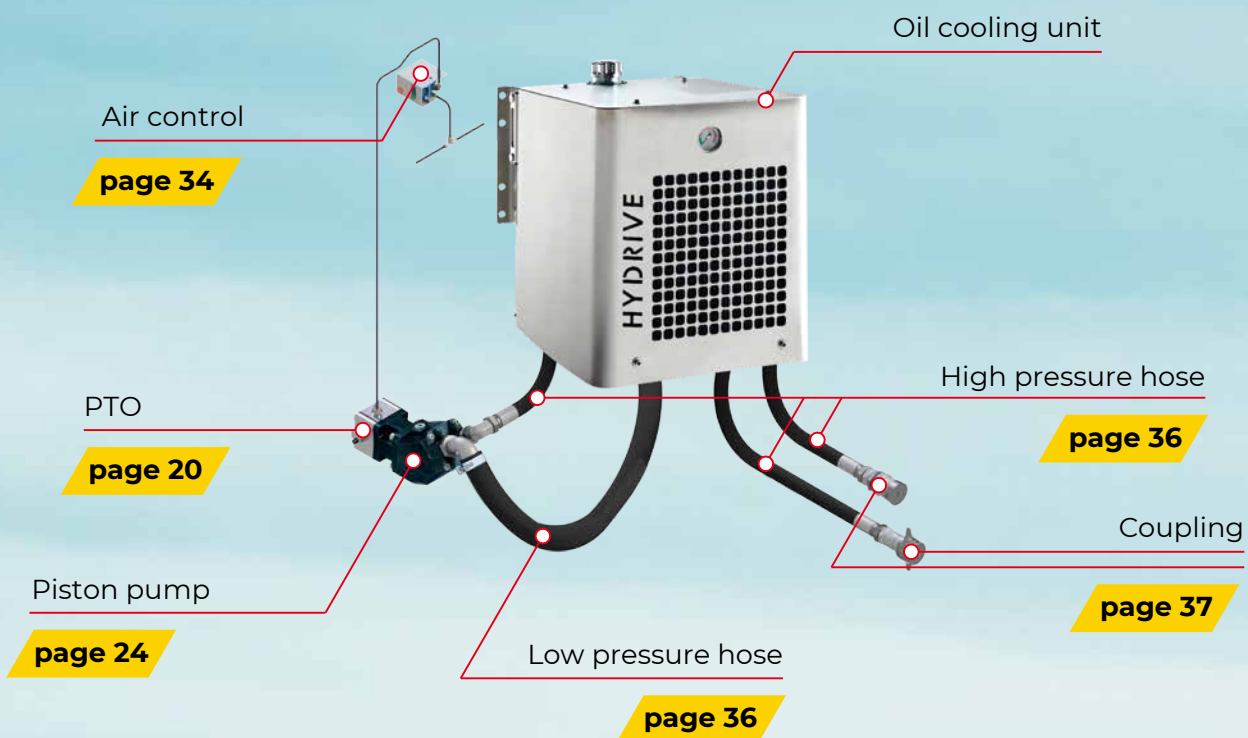



FRONT END CYLINDERS, HYVA ALPHA

Hyva is the world leader in the production of front end telescopic tipping cylinders for rear end tipping vehicles of all kinds.

We offer a full range of cylinder types. Our most popular cylinders are FC (cover type) and FE (eye type) and all of our cylinders are available in the newest generation of Hyva Alpha.

The most important features of Alpha cylinders are:

- Smaller dimensions and lower weight while sustaining the key work parameters
- More robust and suitable to work with 250 bar pressure
- Two duty versions – standard (STD) for construction applications and heavy duty (HD) for mining and difficult conditions. Hard chrome options for both versions
- Cast brackets in maintenance free or greased versions
- Optimized and modern design of the cylinder and brackets

Popular FC type cylinders

Part no.	Description	Pressure [bar]	Lifting Capacity [T]	Weight [kg]	Oil Volume [L]	K [mm]
70124230	FC A118-3-03880-000-K0343	250	33 - 55	190	34	343
70524210	FC A129-3-03880-000-K0343	250	44 - 58	206	41	343
70125364	FC A137-4-04980-004-K1050	250	35 - 52	202	52	1050
70525390	FC A149-4-04660-000-K0343	250	46 - 59	230	59	343
70525408	FC A149-4-05180-000-K0343	250	45 - 59	250	65	343
70526450	FC A169-5-05830-000-K0343	250	46 - 58	282	87	343
70526490	FC A169-5-06230-000-K0343	250	45 - 57	295	93	343
70526528	FC A169-5-06480-014-K1050	250	45 - 56	292	97	1050
70526580	FC A169-5-07130-000-K0343	250	44 - 56	329	106	343
70526718	FC A169-5-08130-000-K0486	190	33 - 47	369	121	486
70527550	FC A191-5-06830-000-K0343	250	65 - 79	405	134	343



Popular FE type cylinders

Part no.	Description	Pressure [bar]	Lifting capacity [T]	Weight [kg]	Oil volume [L]	K [mm]
70544230	FE A129-3-03880-001-K1600	250	43 - 59	142	41	1600
70545296	FE A149-4-04660-009-K1485	250	45 - 60	172	59	1485
70545360	FE A149-4-04980-001-K1530	250	45 - 60	180	63	1530
70546526	FE A169-5-06230-019-K1559	190	34 - 52	236	93	1559
70546556	FE A169-5-06830-011-K1669	170	30 - 48	257	102	1669
70546584	FE A169-5-07030-019-K1729	170	30 - 42	265	106	1729
70547602	FE A191-5-07130-011-K1732	170	43 - 61	316	139	1732



Popular sealkits for FC/FE cylinders

Part no.	Suitable for cylinder
71907430K	A118-3
71907540K	A137-4
71907541K	A137-4-HD
71908540K	A149-4
71907650K	A157-5
71907651K	A157-5-HD
71908640K	A169-4
71908650K	A169-5
71908651K	A169-5-HD



Cylinder brackets

Part no.	Description
01509130	Lifting bracket right FC 118/129/137/149/157/169/179
01509131	Lifting bracket left FC 118/129/137/149/157/169/179
01506777	Top bracket for FE cylinder
01506181	Chassis bracket FC 118/129/137/149/157/169/179

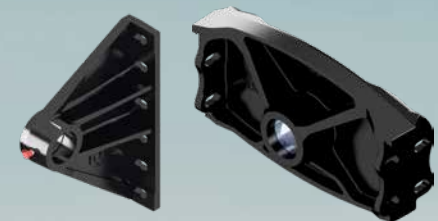

01509130

01506181

Tipper body clamp

Part no.	Description
08102864T	Hyfix body clamp
14897167T	Hyfix bracket steel



08102864T

14897167T

UNDERBODY CYLINDERS AND POWER PACK WETKITS

Hyva offers a wide range of underbody cylinders - telescopic cylinders installed underneath the tipper body - for heavy, medium, and light applications.

The UH range of cylinders, for heavy tipper vehicles, is characterized by a very low closed length and build-in dimensions.

With its unique design and hard-chromed stages, long operating life is guaranteed.

For the complete range of underbody cylinders, we have cylinder Cardan cradles available with different types of knock-off valves for 2- and 3-way tipping applications.

Here we present our most popular cylinders. For more options, please contact Hyva for specific information and advice.



Popular UH cylinders

Part no.	Description	Tipping weight [ton]	Body length [mm]	Weight [kg]	ØW** [mm]	K* [mm]
71423281	UHB 110-3-1203-K320-45-HC	24-27	3100-3400	44	45	320
71424471	UHB 129-3-1661-K370-45-HC	23-23	4000-4400	66	45	370
71425181	UHB 149-4-0980-K324-50-HC	32-32	2900-3200	56	50	324
71425301	UHB 149-6-1423-K321-50-HC	19-23	4100-4600	58	50	321
71426431	UHB 169-7-1584-K300-50-HC	20-24	4500-5000	70	50	300
71426451	UHB 169-6-1618-K339-50-HC	25-25	4500-5000	75	50	339
71427531	UHB 191-7-2131-K349-60-HC	27-31	6100-6800	106	60	349
71427981	UHB 191-4-3417-K520-60-HC	41-41	6600-7300	187	60	520
71428541	UHB 214-10-2197-K250-60-SD-HC	19-24	5900-6600	114	60	250
71428545	UHB 214-9-2252-K250-60-SD-HC	28-32	5900-6600	119	60	250
71428551	UHB 214-8-2281-K320-60-SD-HC	24-28	6600-7300	128	60	320
71428571	UHB 214-7-2329-K365-60-SD-HC	32-32	6600-7300	136	60	365
71428611	UHB 214-8-2489-K350-60-SD-HC	25-29	6600-7300	134	60	350
71428621	UHB 214-9-2558-K260-60-SD-HC	27-32	6600-7300	127	60	260
71429201	UHB 238-9-2008-K250-60-SD-HC	32-32	5400-6000	131	60	250
71429301	UHB 238-10-2221-K250-60-SD-HC	23-29	6100-6800	133	60	250
71429401	UHB 238-9-2458-K250-60-SD-HC	32-32	6500-7200	147	60	250
71429441	UHB 238-8-2518-K250-60-SD-HC	31-32	6600-7300	156	60	250
71429781	UHB 238-10-2721-K250-60-SD-HC	25-32	6600-7300	148	60	250
71429801	UHB 238-9-2818-K250-60-SD-HC	32-32	6600-7300	159	60	250
71429851	UHB 238-11-2986-K251-60-SD-HC	20-28	6600-7300	151	60	251

Popular UM cylinders

Part no.	Description	Tipping weight [ton]	Body length [mm]	Weight [kg]	Hose connection [inch]	ØW** [mm]	K* [mm]
71404203	UMB 129-3-0700-K318-45-½"-HC	15 - 21	2400 - 3100	46	½	45	318
71404421	UMB 129-5-1480-K192-45-½"-HC	6 - 17	4100 - 5400	59	½	45	192
71404537	UMB 129-5-1880-K192-45-½"-HC	6 - 17	4900 - 6500	67	½	45	192
71404365	UMB 129-5-1280-K192-45-½"-HC	6 - 17	3600 - 4900	53	½	45	192
71405291	UMB 149-4-1020-K265-50-¾"-HC	19 - 29	3200 - 4300	62	¾	50	265
71405623	UMB 149-4-2180-K265-50-¾"-HC	20 - 32	5200 - 6900	96	¾	50	265
71405421	UMB 149-5-1480-K258-50-¾"-HC	12 - 23	4200 - 5600	69	¾	50	258
71405537	UMB 149-5-1880-K258-50-¾"-HC	11 - 23	5100 - 6700	79	¾	50	258
71405709	UMB 149-5-2480-K258-50-¾"-HC	13 - 25	5700 - 7700	95	¾	50	258
71405439	UMB 149-6-1540-K245-50-¾"-HC	6 - 17	4300 - 6000	68	¾	50	245
71405681	UMB 149-6-2380-K245-50-¾"-HC	7 - 19	5500 - 7400	89	¾	50	245
71406537	UMB 169-5-1880-K265-50-¾"-HC	18 - 28	5300 - 7000	96	¾	50	265
71406439	UMB 169-6-1540-K258-50-¾"-HC	12 - 23	4500 - 6100	79	¾	50	265
71406509	UMB 169-6-1780-K258-50-¾"-HC	12 - 23	5000 - 6700	86	¾	50	258
71406852	UMB 169-6-2980-K258-50-¾"-HC	13 - 25	6900 - 9200	119	¾	50	258
71407909	UMB 191-5-3180-K270-60-¾"-HC	29 - 40	7200 - 9700	165	¾	60	270
71407511	UMB 191-6-1780-K270-60-¾"-HC	19 - 34	5000 - 6700	107	¾	60	270
71407681	UMB 191-8-2380-K278-60-¾"-HC	7 - 22	5800 - 7600	116	¾	60	278

Popular UL cylinders

Part no.	Description	Tipping weight [ton]	Body length [mm]	Weight [kg]	Hose connection [inch]	ØW** [mm]	K* [mm]
71418297	ULB 110-5-1040-K169-40-½"-HC	4 - 9	3000 - 4100	28	½	40	169
71418349	ULB 110-5-1240-K169-40-½"-HC	4 - 9	3400 - 4600	32	½	40	169
71418441	ULB 110-5-1540-K169-40-½"-HC	4 - 9	4000 - 5500	36	½	40	169

* K – Built in dimension / closed length

** W – Cylinder pin diameter

Boltable brackets

Part no.	Description	ØW** [mm]	Weight [kg]
73105071	Bracket to bolt D40	40	1,1
73105073	Bracket to bolt D45	45	1,0
73105076	Bracket to bolt D50	50	1,4
73105079	Bracket to bolt D60	60	1,6

Welded brackets

Part no.	Description	ØW** [mm]	Weight [kg]
73105035	Bracket to weld D50	50	1,5
73105036	Bracket to weld D60	60	2,1
73105037	Bracket to weld D50 K.O UH TYPE 1	50	2,4
73105038	Bracket to weld D50 K.O UH TYPE 2	50	2,5
73105039	Bracket to weld D60 K.O UH TYPE 3	60	2,8



Cylinder cradles

Part no.	Description	ØW** [mm]	Weight [kg]
73104011	Cradle UL 110	40	8,3
73104021	Cradle UM 129	50	13,6
73104023	Cradle UM 129 Pneu KO	50	19,4
73104031	Cradle UM 149	50	20,3
73104033	Cradle UM 149 Pneu KO	50	25,7
73104041	Cradle UM 169	50	26,5
73104043	Cradle UM 169 Pneu KO	50	31,8
73104051	Cradle UM 191	60	39,3
73104053	Cradle UM 191 Pneu KO	60	45,4
73209014	Cradle UH 110-129	50	18,3
73209015	Cradle UH 110-129 Pneu KO	50	20,3
73209016	Cradle UH 110-129 Hydr KO	50	22,9
73209024	Cradle UH 149-169	50	30,9
73209025	Cradle UH 149-169 Pneu KO	50	33,5
73209026	Cradle UH 149-169 HYDR KO	50	36,1
73209034	Cradle UH 191-238	60	50,7
73209035	Cradle UH 191-238 Pneu KO	60	53,5
73209036	Cradle UH 191-238 Hydr KO	60	56,0



Power Pack is a compact electro hydraulic unit consisting of 12V or 24V electric motor, hydraulic pump, oil tank and control valve. It is controlled with in-cab switches or outer control connected with cables. This solution is advised for tipper applications with underbody cylinders where PTO wetkit is not preferred. Power Pack kits are also often used for driving hydraulic systems on low bed trailers, silo trailers, small cranes and others.

Power Pack system

Part no.	Description
14553000	Power Pack 12V, 2kW, 3.1cc, 10 L
14553001	Power Pack 12V, 2kW, 3.1cc, 15 L
14553500	Power Pack 24V, 3kW, 3.1cc, 10 L
14553501	Power Pack 24V, 3kW, 3.1cc, 15 L
02070111	Limit switch mini tipper electric NC
02070121	Switch panel electric TIP/LOWER
14552657	2 button remote control (2m) cable

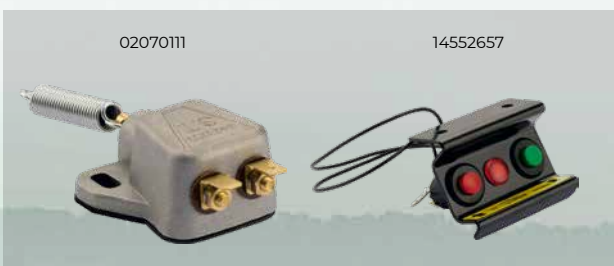



POWER TAKE OFF (PTO)

Power take off is a mechanical auxiliary device transferring drive from truck gearbox to hydraulic pumps, compressors and other similar units. Clutch dependant PTOs mounted on the gearbox are described by parameters such as transferred torque, ratio, rotation direction, mounting position and connection / output type (flange, shaft etc.).

Hyva offers PTOs for the majority of trucks and gearboxes for several applications.

For more information and help with PTO selection please contact your local Hyva representative.

Power take off



Mounting kits

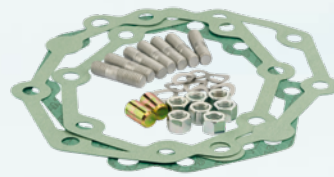
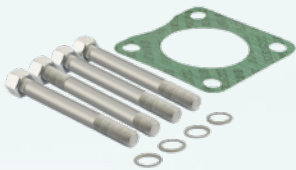

Quill shafts



ZF manual



Volvo



ZF Traxon

Power take off – Volvo

Gearbox type	Torque [Nm]	Rotation direction	PTO	Mounting kit	Quill shaft [mm]
VT 2412	1000	↻	021215010	021457000	021313000 (261)
	300	↻	021215022	021463000	
VT 2412 + IT	1000	↻	021215010	021457000	021313010 (297)
	300	↻	021215022	021463000	
AT 2612	1000	↻	021215010	021457000	021313001 (225,3)
	300	↻	021215022	021463000	

Power take off – SCANIA

Gearbox type	Torque [Nm]	Rotation direction	Rear PTO	Side PTO	Mounting kit
GR 875/905 GRS 895/905	450	↻	021211076	n/d	021465006
GRS 890 GRS 900 GRS 920	480	↻	021211071	n/d	021461000
GRS0 905	370	↻	021211075	n/d	021465006
GR 975-895	n/d	↻	n/d	02090471H	n/d
GR905-GRS905	n/d	↻	n/d	02090469H	n/d
GRS0 905	n/d	↻	n/d	02090470H	n/d

Power take off – MERCEDES

Gearbox type	Torque [Nm]	Rotation direction	PTO	Mounting kit	Quill shaft [mm]
G 221-16	1000	↻	021215010	021457000	021307002 (249)
	300	↻	021215022	021463000	
G 221-16 IT	1000	↻	021215010	021457000	021301000 (275)
	300	↻	021215022	021463000	

Power take off – ZF

Gearbox type	Torque [Nm]	Rotation direction	PTO	Mounting kit	Quill shaft [mm]
16S-1620 TD	1000	↻	021215010	021457000	021314000 (213,5)
	300	↻	021215022	021463000	
16S-1621 TD+IT	1000	↻	021215010	021464002	021314002 (248,5)
	250	↻	021215022	021416001	
12AS-2330 TD	1000	↻	021215010	021457000	021314005 (248,5)
	300	↻	021215022	021463000	
12AS2331 TD+IT	1000	↻	021215010	021464004	021314004 (272,5)
	300	↻	021215022	021464000	
16TX-1640 TD	300	↻	021215022	021463000	021314049

Adaptors

Part no.	Description
021430005	Flange kit DIN 10 for PTO code 17/18
02050531H	Adaptor 4H – Flange kit DIN 10





HYDRAULIC GEAR PUMPS

Hyva offers a wide range of hydraulic pumps for all offered wetkits and applications. Our most popular pumps are gear versions mounted on gearbox PTOs.

Gear pumps are mainly used for tipping applications on tractors or truck tippers. Due to highest quality of production and 250 bar working pressure standards these pumps are very durable even in the most demanding heavy duty applications.

The pumps are offered in several connection versions, the most popular are 3-hole and 4-hole mounting patterns (3H, 4H).

The great majority of Hyva pumps are bi-rotational. The rotation direction is determined by connection of the hoses without the need to disassemble the pump to change its rotation.

Hyva gear pumps are equipped with a unique safety system of leakage indicator to avoid internal leakages of oil from the hydraulic system to the gearbox and vice versa.

Gear pump 4H

1 Type plate

2 Drive shaft

3 Side port

4 Rear port

5 Connection flange 4H



Gear pumps – 4H versions

Part no.	Description	Max working pressure [bar]	Pressure port [inch]	Suction port [inch]
14562005	Gear pump 035L-BI-4H-BRITE	250	3/4	3/4
14562010	Gear pump 052L-BI-4H5-BRITE	250	1	1
14562015	Gear pump 061L-BI-4H5-BRITE	250	1	1
14571224	Gear pump 082L-BI-4H5-2S	250	1	1
14562091	Gear pump 082L-BI-4H5-2R	250	1 1/4	1 1/4
14562325	Gear pump 082L-BI-4H	225	1	1
14562030	Gear pump 092L-BI-4H5-BR	250	1 1/4	1 1/4
14562093	Gear pump 100L-BI-4H5-2R	250	1 1/4	1 1/4
14562095	Gear pump 100L-BI-4H5-2S	250	1 1/4	1 1/4
14562036	Gear pump 113L-BI-4H5-4P	250	1 1/4	1 1/4

Part no.	Seal kit for gear pump 4H
02460001	Seal kit Brite BI Gear pump 035L - 061L
02460005	Seal kit Brite BI Gear pump 092L - 113L
02460007	Seal kit Brite BI Gear pump 82L - 100L
14600100	Seal kit Brite BI Gear pump 14562325
14624850	Gasket for ISO 4H pump

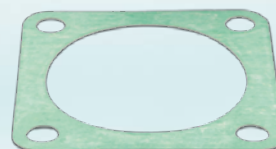

Gear pumps – 3H versions

Part no.	Description	Max working pressure [bar]
14563028	Gear pump 020L-BI-3H	250
14563033	Gear pump 025L-BI-3H	250
14563043	Gear pump 032L-BI-3H	250
14563034	Gear pump 035L-BI-3H	250
14563052	Gear pump 052L-BI-3H	250
14563061	Gear pump 061L-BI-3H	250
14563082	Gear pump 082L-BI-3H	250



Part no.	Connection adaptors
021419601	Connection kit PTO UNI 3H – Pump 3H 27 L
021419605	Drive kit DIN-13 Pump to UNI-3H PTO 20, 25, 32 L
021415006	Adaptor PTO UNI 3H – Pump ISO 4H
021415022	Adaptor 4H SE PTO UNI 3H Pump SB
02050010H	Pump connection kit UNI-3H





HYDRAULIC PISTON PUMPS

Piston pumps are used in more demanding hydraulic systems to drive systems such as moving floors, cranes, hook- and skiploaders, gas and liquid tankers.

Such pumps are the ideal choice for systems where high working pressure and long working time is required.

Our most popular piston pumps are bent axis 4H pumps. We offer a wide range of sizes with working pressure up to 350 bar. In addition to single flow pumps, Hyva offers a full range of twin flow pumps for scrap and timber cranes.

Piston pump 4H

1 Type plate

2 Drive shaft

3 Connection flange 4H

4 Pressure port

5 Suction port



Piston pumps single flow

Part no.	Description	Rotation direction	Max working pressure [bar]	Pressure port [inch]	Suction port [inch]
14569025	Piston pump 034L-LH-4H-BA	↻	350	3/4	1
14569020	Piston pump 034L-RH-4H-BA	↻	350	3/4	1
14569017	Piston pump 040L-LH-4H-BA	↻	350	3/4	1
14569016	Piston pump 040L-RH-4H-BA	↻	350	3/4	1
14569001	Piston pump 047L-LH-4H-BA	↻	350	3/4	1 1/4
14569000	Piston pump 047L-RH-4H-BA	↻	350	3/4	1 1/4
14569005	Piston pump 064L-LH-4H-BA	↻	350	3/4	1 1/4
14569004	Piston pump 064L-RH-4H-BA	↻	350	3/4	1 1/4
14569007	Piston pump 080L-LH-4H-BA	↻	250	3/4	1 1/4
14569006	Piston pump 080L-RH-4H-BA	↻	250	3/4	1 1/4
14569305	Piston pump 084L-LH-4H-BAHP	↻	350	1	1 1/4
14569300	Piston pump 084L-RH-4H-BAHP	↻	350	1	1 1/4
14569315	Piston pump 096L-LH-4H-BAHP	↻	350	1	1 1/4
14569310	Piston pump 096L-RH-4H-BAHP	↻	350	1	1 1/4
14569325	Piston pump 108L-LH-4H-BAHP	↻	350	1	1 1/4
14569320	Piston pump 108L-RH-4H-BAHP	↻	350	1	1 1/4
14569225	Piston pump 130L-LH-4H-BAHP	↻	250	1	1 1/4
14569223	Piston pump 130L-RH-4H-BAHP	↻	250	1	1 1/4

Piston pumps twin flow

Part no.	Description	Rotation direction	Max working pressure [bar]
14569025	Piston pump F2-042L/042L-R-4H	↻	350
14569020	Piston pump F2-042L/042L-L-4H	↻	350
14569017	Piston pump F2-053L/053L-R-4H	↻	350
14569016	Piston pump F2-053L/053L-L-4H	↻	350
14569001	Piston pump F2-055L/028L-R-4H	↻	350
14569000	Piston pump F2-055L/028L-L-4H	↻	350
14569005	Piston pump F2-070L/070L-RL-4H	↻	350
14569004	Piston pump F2-070L/070L-L-4H	↻	350
14569007	Piston pump F2-070L/035L-R-4H	↻	350
14569006	Piston pump F2-070L/035L-L-4H	↻	350





HYDRAULIC TIPPING VALVES, HT 1150 SERIES

HT 1150 series valves are suitable for tipping applications in systems where the maximum oil flow does not exceed 150 L/min.

It is a very good choice for standard work duty tipper trucks and smaller tipping semitrailers.

This series is designed in a unique way allowing the valve to be mounted either on the tank mounting plate or directly on the Hyva cylinder SAE port.

If mounted directly on the cylinder, it also acts as a hose burst valve in the event of high pressure hose failure.

The maximum working pressure is secured by a fixed cartridge design, characteristic of Hyva HT valves.

Hydraulic tipping valves HT 1150 series

- | | |
|--|--|
| 1 Pneumatic connection (TIP) 6 mm | 4 Pressure gauge connection port |
| 2 Pneumatic connection (LOWER) 6 mm | 5 Tank connection |
| 3 Pump connection | 6 Pressure relief cartridge |
| | 7 Cylinder connection SAE |
| | 8 Lowering speed adjustment screw |



Tipping valves HT 1150 series

Part no.	Description	Max. working pressure
		[bar]
14767213	Tipping valve HT-TNK/SAE-1150-135-P3/4"	135
14767215	Tipping valve HT-TNK/SAE-1150-150-P3/4"	150
14767217	Tipping valve HT-TNK/SAE-1150-170-P3/4"	170
14767219	Tipping valve HT-TNK/SAE-1150-190-P3/4"	190
14767222	Tipping valve HT-TNK/SAE-1150-220-P3/4"	220
14767225	Tipping valve HT-TNK/SAE-1150-250-P3/4"	250
14767263	Tipping valve HT-TNK/SAE-1150-135-P1"	135
14767265	Tipping valve HT-TNK/SAE-1150-150-P1"	150
14767267	Tipping valve HT-TNK/SAE-1150-170-P1"	170
14767269	Tipping valve HT-TNK/SAE-1150-190-P1"	190
14767272	Tipping valve HT-TNK/SAE-1150-220-P1"	220
14767275	Tipping valve HT-TNK/SAE-1150-250-P1"	250

Pressure relief cartridges

Part no.	Max. working pressure [bar]
14772135	135
14772150	150
14772170	170
14772190	190
14772200	200
14772220	220
14772250	250
14772280	280
14772350	350



Mounting parts

Part no.	Description
14844010	Seal kit PT/JT/HT valve
14735208	Mounting kit HT1220 valve on chassis*

* supplied separately





HYDRAULIC TIPPING VALVES, HT 1220 SERIES

HT 1220 series valves are high performance valves suitable for the most demanding tipping applications with maximum oil flow of 220 L/min.

It is a very good choice for heavy duty and high speed tipping systems.

Hyva offers these valves in two mounting options, either on the tank mounting plate or directly on the Hyva cylinder SAE port.

If mounted directly on the cylinder it also acts as a hose burst valve in case of high pressure hose failure.

The maximum working pressure is secured by a fixed cartridge design, characteristic of Hyva HT valves. Its design guarantees the highest level of safety to avoid high pressure peaks during heavy duty operation.

Hydraulic tipping valves HT 1220 series

- | | |
|--|---|
| 1 Cylinder connection | 6 Tank connection |
| 2 Additional tank return connection | 7 Pressure gauge connection port |
| 3 Lowering speed adjustment screw | 8 Pneumatic connection (LOWER) 6mm |
| 4 Pump connection | 9 Pneumatic connection (TIP) 6mm |
| 5 Pressure relief cartridge | |

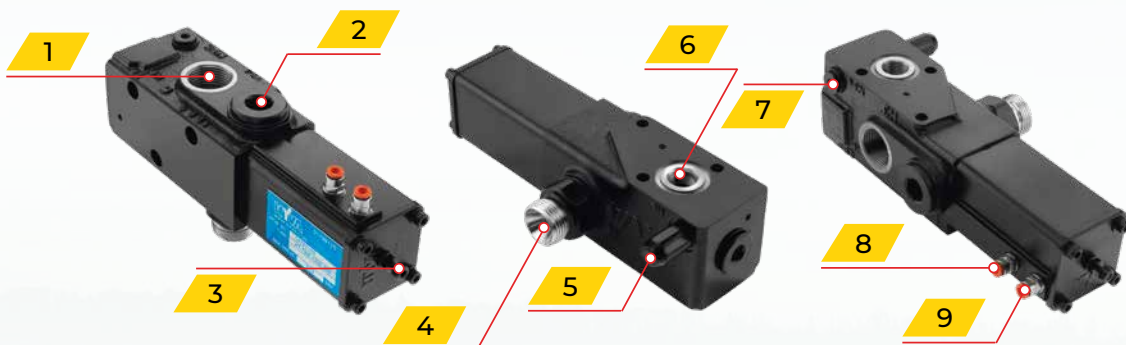

Tipping valves HT 1220 series

Part no.	Description	Max. Working pressure
		[bar]
14767111	Tipping valve HT-TNK-1220-110-P1"	110
14767113	Tipping valve HT-TNK-1220-135-P1"	135
14767115	Tipping valve HT-TNK-1220-150-P1"	150
14767117	Tipping valve HT-TNK-1220-170-P1"	170
14767119	Tipping valve HT-TNK-1220-190-P1"	190
14767122	Tipping valve HT-TNK-1220-220-P1"	220
14767125	Tipping valve HT-TNK-1220-250-P1"	250
14767128	Tipping valve HT-TNK-1220-280-P1"	280
14767135	Tipping valve HT-TNK-1220-350-P1"	350

Dual pressure tipping valves HT 2220 series

Part no.	Description	Working pressure [bar]*	
		LP	HP
14767172	Tipping valve HT-TNK-2220-170-220-P1"	170	220
14767175	Tipping valve HT-TNK-2220-170-250-P1"	170	250
14767172	Tipping valve HT-TNK-2220-190-220-P1"	190	220
14767175	Tipping valve HT-TNK-2220-190-250-P1"	190	250

* Maximum working pressure is set by turning a lever (manually or pneumatically) into HP (Higher Pressure) or LP (Lower Pressure) option.

Dual pressure tipping valves HT 2220 series

- | | |
|--|---|
| 1 Pneumatic connection (TIP)
6mm | 6 Pump connection |
| 2 Pneumatic connection (LOWER)
6mm | 7 Tank connection |
| 3 Additional tank return connection | 8 Pressure relief cartridge |
| 4 Cylinder connection | 9 Pressure relief cartridge |
| 5 LP/HP pressure selector | 10 Pressure gauge connection port |
| | 11 Lowering speed adjustment screw |

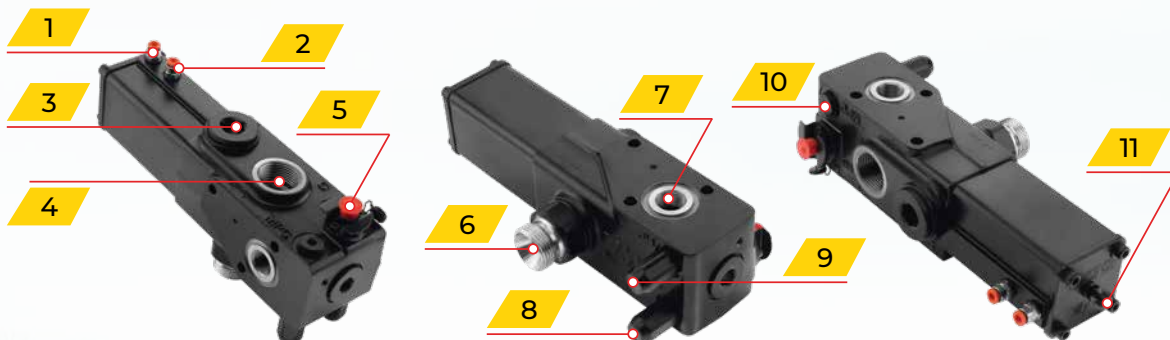

OTHER VALVES

Apart from tipping valves, Hyva also offers a range of other valves which are used in several wetkit types. These are pressure relief valves, knock off valves, shut off valves and others used for tipping, moving floor, two line and other hydraulic systems.

Pressure relief valves

Part no.	Description	Connections [inch]	Max. working pressure [bar]	Oil flow [L/min]
01319880	Pressure relief valve adj. (alu)	¾"	50-210	100
01319885	Pressure relief valve adj. (steel)	¾"	180-350	100
01319890	Pressure relief valve adj. (steel)	1"	180-350	100

Other valves

Part no	Description	Connections [inch]	Max. working pressure [bar]	Oil flow [L/min]
021418011	Diverter valve manual-3/3	¾"	400	110
14767620	Tipping valve pneumatic 80L	⅜" - ¾" - 1½"	300	80

Knock off valves

Part no.	Description	Connections	Max. working pressure [bar]
14720171	Knock-off valve 2/2 60L normally open	⅜"	350
14720211	Knock-off valve 2/2 120L normally open	¾"	350
14700506	Knock-off valve pneumatic with support	6 mm	
14700575	Knock-off valve pneumatic Heavy Duty incl. MK	6 mm	

Ball valves

Part no.	Description	Connection [inch]
14780980	Ball valve 1½" BSP LP lever operated	1½" BSP
14780981	Ball valve 1½" BSPOT+NUT - 1½" BSP	1½" BSP

Pressure relief valves



Knock off valves



Diverter valves



Ball valves



OIL TANKS

Hyva offers a complete range of oil tanks manufactured from the highest quality materials – steel and aluminium. We offer several mounting possibilities – behind the cabin, on the side of the vehicle, in the cylinder cradle and others. All of our tanks are compatible with Hyva air breathers and return oil filters. Hyva HT 1150 and 1220 series tipping valves can be mounted either on mounting plates or directly on the return filter. The tanks are optimized for size, weight and working volume to deliver maximum efficiency in the hardest working conditions.

Side mounted tanks for mounting on truck frame (SM)

	Part no.	Description	Dimensions (L x H x W) [mm]	Mounting kit
SM ALPHA Steel Single (valve) Mounting plate Double support	14017254	Oil tank SM – 155L/130L-MP-MR	706 x 636 x 380	14020166 / 14020167
	14017258	Oil tank SM – 179L/150L-MP-MR	706 x 636 x 440	14020166 / 14020167
	14017262	Oil tank SM – 201L/170L-MP-MR	706 x 636 x 495	14020166 / 14020167
	14017266	Oil tank SM – 236L/200L-MP-MR	706 x 636 x 580	14020166 / 14020167

	Part no.	Description	Dimensions (L x H x W) [mm]	Mounting kit
SM ALPHA Single (valve) Mounting plate Single support	14018292	Tank kit SM – 132L/112L-AL-MP with support	706 x 636 x 330	14020166 / 14020167
SM ALPHA Single (valve) Mounting plate Double support	14018270	Oil tank SM – 155L/130L-AL-MP-MR	706 x 636 x 380	14020166 / 14020167
	14018272	Oil tank SM – 179L/150L-AL-MP-MR	706 x 636 x 440	14020166 / 14020167
	14018274	Oil tank SM – 201L/170L-AL-MP-MR	706 x 636 x 495	14020166 / 14020167
	14018276	Oil tank SM – 236L/200L-AL-MP-MR	706 x 636 x 580	14020166 / 14020167

	Part no.	Description	Dimensions (L x H x W) [mm]	Mounting kit
Small SM tank	14022115	Oil tank SM – 50L/35L-MF	590 x 390 x 410	Direct mounting
	14022116	Oil tank SM – 34L/23L-14L-MF	410 x 390 x 410	Direct mounting



Tanks mounted on cylinder cradle (CM)

	Part no.	Description	Dimensions (L x H x W) [mm]	Mounting kit
CM ALPHA Steel	14016504	Oil tank CM – 065L/048L-039L-MF	525 x 280 x 500	14021010 / 14021013
	14016509	Oil tank CM – 083L/060L-049L-MF	525 x 280 x 620	14021010 / 14021013
	14016518	Oil tank CM – 095L/068L-055L-MF	525 x 280 x 700	14021010 / 14021013
	14016580	Oil tank CM – 110L/090L-081L-072L-MF	700 x 280 x 620	14021014
CM ALPHA Aluminium	14016519	Oil tank CM – 101L/073L-060L-AL-MF	525 x 280 x 700	14021010 / 14021013
	14016581	Oil tank CM – 110L/090L-081L-072L-AL-MF	700 x 280 x 620	14021014

Tanks mounted behind truck cabin (RM)

	Part no.	Description	Dimensions (L x H x W) [mm]	Mounting kit
RM ALPHA Standard	14015050	Oil tank RM – 240L/198L-179L-159L-MF	284 x 700 x 1336	14021023 / *
	14015070	Oil tank RM – 240L/198L-179L-159L-AL-MF	284 x 700 x 1336	14021023 / *
Long Low RM tanks	14015077	Oil tank RM – 152L/123L-109L-AL-MF-LL	350 x 350 x 1370	14221615 / *
	14015076	Oil tank RM – 177L/144L-128L-AL-MF-LL	350 x 350 x 1600	14221615 / *
High volume RM tank	14015075	Oil tank RM – 317L/284L-MF-HV	521 x 421 x 1600	14020530 / *
Slim RM tanks	14015221	Oil tank RM – 081L/065L-059L-052L-MF	700 x 200 x 620	14021024 / 14021025
	14015222	Oil tank RM – 080L/065L-058L-052L-AL-S2-MF	700 x 200 x 620	14021024 / 14021025
	14015223	Oil tank RM – 136L/110L-099L-085L-AL-MF	700 x 200 x 1030	Direct mounting / *

* Possible with oil tank mounting kit (14221620)



Other components

	Part no.	Description
Standard Air breater	08102116	Filler/breather assembly complete
	08102117	Filter element to suit 08102116
	08280071A	Extension tube for air breather, Height = 150 mm
Return line filter - house version	14780358	Tank return filter house kit, inner Length = 323 mm
	14780351	Tank return filter house kit, inner Length = 449 mm
	14780352	Tank return filter house kit, inner Length = 549 mm
	14780353	Tank return filter house kit, inner Length = 649 mm
Return line filter - plate version	14895926	Tank return filter plate kit, inner Length = 323 mm
	14895923	Tank return filter plate kit, inner Length = 449 mm
	14895924	Tank return filter plate kit, inner Length = 549 mm
	14895925	Tank return filter plate kit, inner Length = 649 mm
	01317987	Adaptor kit 90 for return filter 1" BSPOTC
Filter element	14896992	Return filter element for plate and house version
Spy eye	08102121	1" Level spy eye with gasket



AIR CONTROLS

Hyva offers a wide range of configurations in air controls for tipping valves, PTOs and other related components with air pressure from 5 to 12 bar. Our options include spring return levers, fixed position options, automatic PTO disengagement and several others. Hyva air controls are proportional on lowering function for maximum precision and safety.

PTO and tipping valve control

Part no.	Tipping position fixed	Auto disengagement of PTO
14750644H	YES	NO
14750646H	NO	NO
14750650H	YES	YES
14750652H	NO	YES
14750665H	YES	-
14750667H	NO	-

Part no.	Description
14751082H	TIP-PTO control-AIR-TF/LF-PNL
14750119K	Air tube kit PTO/Valve control - 6mm/25m
14752532H	Support Tip control 147506-serie plastic
14752535H	Fixing kit support international



MULTI SECTIONAL TIP CONTROL

Multi-sectional controls are used to control the tipping cylinder and a number of additional functions, such as opening of the rear door, sheeting systems, side boards and others. Hyva can offer sets of controllers that can be customised to the needs of a given application and the required number of control sections.

Part no.	Description	Pos.
14750430	Tip control flat model MS-AIR-TF/LF	1
14750440	Tip control flat model MS-AIR-TS/LF	1
14750455	Tip control flat model-AIR-3/2 button	2
14750460	Tip control flat model-AIR 4/3 button	3

Part no.	Description
14750511	Mounting kit 1 section flat model
14750512	Mounting kit 2 sections flat model
14750513	Mounting kit 3 sections flat model



1



2



3

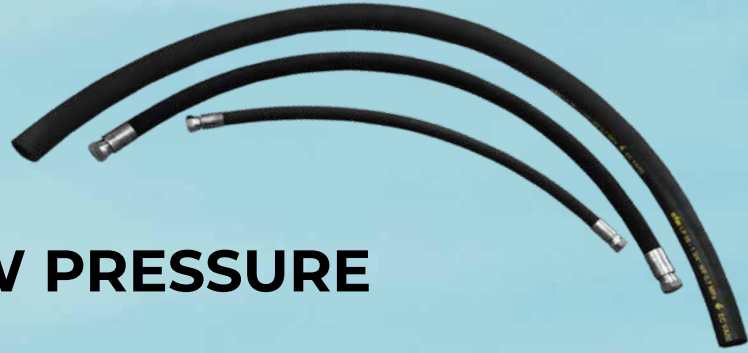

HIGH AND LOW PRESSURE HOSES

Hyva offers a full range of high pressure and low pressure (suction) hoses in several diameters, lengths and coupling types. Our pressure hoses are high quality, factory made products suitable to work with Hyva Alpha standards of 250 bar working pressure. Below our most popular items are presented.

Low pressure suction hoses

Hoses for connecting oil tank and pump

Part no.	Description
14795120	Hose 1¾"-LP-28-02000
14795853	Hose 2"-LP-32-02000
14795103	Hose 1¾"-LP-28-MB
14796600	Hose clip for LP28 reinforced
09223001	Hose fixing P-clip D=61 mm (LP28)
14796612	Hose clip LP32 Heavy Duty 60-63 mm

High pressure hoses

Part no.	Description	Part no.	Description
14789483	Hose ½"-HP-08-00700-00-00 310 bar	14790087	Hose ¾"-HP-12-03500-00-00 280 bar
14789486	Hose ½"-HP-08-01000-00-00 310 bar	14790075	Hose ¾"-HP-12-04000-00-00 280 bar
14789504	Hose ½"-HP-08-01500-00-00 310 bar	14790707	Hose 1"-HP-16-00700-00-00 250 bar
14789510	Hose ½"-HP-08-02000-00-00 310 bar	14790710	Hose 1"-HP-16-01000-00-00 250 bar
14789530	Hose ½"-HP-08-02500-00-00 310 bar	14790712	Hose 1"-HP-16-01200-00-00 250 bar
14789549	Hose ½"-HP-08-03000-00-00 310 bar	14790715	Hose 1"-HP-16-01500-00-00 250 bar
14789553	Hose ½"-HP-08-03500-00-00 310 bar	14790720	Hose 1"-HP-16-02000-00-00 250 bar
14790026	Hose ¾"-HP-12-01000-00-00 280 bar	14790725	Hose 1"-HP-16-02500-00-00 250 bar
14790002	Hose ¾"-HP-12-01200-00-00 280 bar	14790730	Hose 1"-HP-16-03000-00-00 250 bar
14790038	Hose ¾"-HP-12-01500-00-00 280 bar	14790735	Hose 1"-HP-16-03500-00-00 250 bar
14790040	Hose ¾"-HP-12-02000-00-00 280 bar	14790740	Hose 1"-HP-16-04000-00-00 250 bar
14790051	Hose ¾"-HP-12-02500-00-00 280 bar	14790745	Hose 1"-HP-16-04500-00-00 250 bar
14790063	Hose ¾"-HP-12-03000-00-00 280 bar	14790750	Hose 1"-HP-16-05000-00-00 250 bar

HP 08-00700-00-00 14789 483

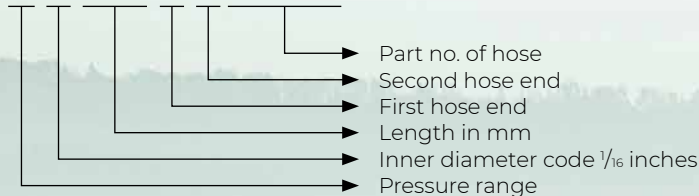

QUICK RELEASE COUPLINGS

Hyva offers quick release couplings for the easy and safe connecting and disconnecting of hydraulic hoses. The most common application is the connection between tractor unit and semitrailer.

Our standard type is a screwed coupling which is safe and robust for heavy duty working conditions. High quality of design and production ensure long and safe operation with high pressure Hyva Alpha systems.



Screwed couplings

Part no.	Description
01332600	Quick Release coupling DN16 3/4" female
01331605	Quick Release coupling DN16 3/4"-1 1/4" male
01332610	Quick Release dust cap 3/4" for 01331605
01332625	QR coupling DN25 1" screw-on female
01332630	QR coupling DN25 1" screw-on male
01332635	Quick Release dust cap 1" for 01331630
01332500	Quick release mounting plate DN16 W1 3/4"
01332569	Quick release mounting plate DN20 W2 1/8"

BONDED SEALS

Hyva bonded seals are used for several connections within Hyva hydraulic systems. Very often these underestimated parts are critical parts to ensure leakage free operation of heavy duty systems. Hyva offers high quality bonded seals, consisting of steel and rubber ring, which are suitable for high pressures and temperatures.

Bonded seals

Part no.	Size	Part no.	Size
01206801	1/8"	01206850	3/4"
01206813	1/4"	01206862	7/8"
01206825	3/8"	01313848	1"
01206837	1/2"	01206874	1 1/4"
01206849	5/8"	01206898	1 1/2"



LOW PRESSURE ADAPTORS

Low pressure adaptors and pillars are used in the suction line between oil tank and pump either by threaded connections or by hose clamps.

Straight adaptors

Part no.	Description	D1 [inch]	D4 [mm]
14500589	Hose pillar LP 20 - 00 - 1" BSPOT	1	32
14799000A	Hose pillar LP 28 - 00 - 1" BSPOT	1	44
14799005A	Hose pillar LP 28 - 00 - 1¼" BSPOT	1¼	44
14799015A	Hose pillar LP 28 - 00 - 1½" BSPOT	1½	44
14535328	Hose pillar LP 32 - 00 - 1¼" BSPOT	1¼	51
14500492	Hose pillar LP 32 - 00 - 1½" BSPOT	1½	51

90 degree adaptors

Part no.	Description	D1 [inch]	D4 [mm]
14799020A	Hose pillar LP 28 - 90 - 1" BSPOT	1	44
14799025A	Hose pillar LP 28 - 90 - 1¼" BSPOT	1¼	44
14799050A	Hose pillar LP 28 - 90 - 1½" BSPOT	1½	44

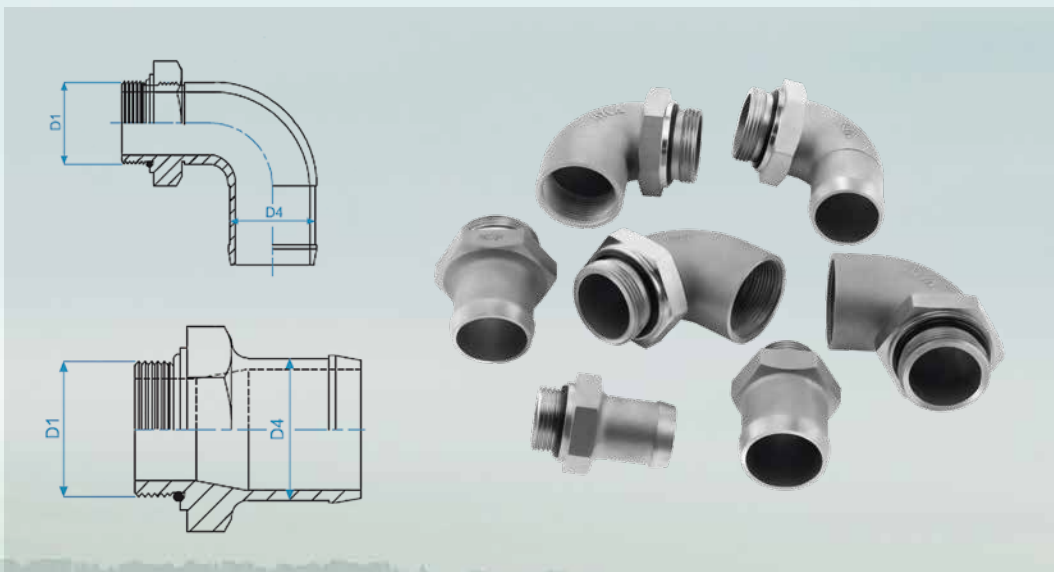

HIGH PRESSURE ADAPTORS

Hyva high pressure adaptors are critical parts used for all possible hydraulic system installations of mobile hydraulics. The quality of these parts is critical for safe, leakage free systems and long life operation of our systems in the most demanding working conditions.

Straight adaptor

Part no.	D1 [inch]	D2 [inch]
01317802	1/8	1/4
14799300	1/4	1/4
01317506	1/4	3/8
01317704	1/4	1/2
013 17690	3/8	3/8
01317805	3/8	1/2
01317706	3/8	3/4
01317714	1/2	3/4
01317702	5/8	3/4
01222661	3/4	3/4
14799080	3/4	1
14500565	1	1 1/4
01317 933	1	1
01222107	1	1 1/4
14500577	1	1 1/2

90 degree swivel adaptor

Part no.	D1 [inch]	D2 [inch]
01317975	1 1/4	1 1/4
01317971	1/2	1/2
01317969	3/4	3/4
14799054	1	3/4
01317982	1	1

Straight swivel adaptor

Part no.	D1 [inch]	D2 [inch]
01222909	3/4	3/4
01223677	1	3/4
14799108	1	1

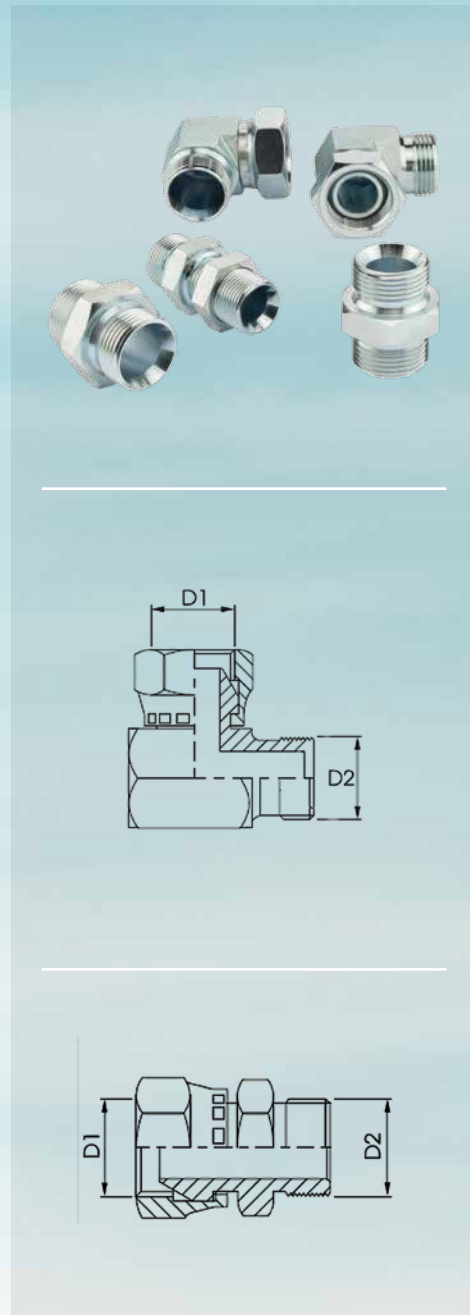

INTERESTING MOUNTING EXAMPLES

Several interesting examples of mounting options are available with Hyva wet kits. These options allow mounting of the system in the space available, in several demanding positions and applications. For every customized request Hyva can offer a competitive and high quality solution.



Oil tank behind cabin on 4 axle tractor unit



Mounting bracket for quick release couplings



Hose swivel arm



Quick release couplings in the front of the tractor

Quick release couplings in the rear of the tractor



Tipping valve mounted on the return filter



SM tank with hose guide arm



Low RM tank



110 countries
+3,500 employees
20,000 customers
+30 subsidiaries
14 production facilities



Hyva is a leading provider of innovative and highly efficient transport solutions for commercial vehicles used in transport, construction, mining, materials handling and environmental service industries.

Founded in 1979 in the Netherlands, the company has a global presence with more than 30 wholly owned subsidiaries, extraordinary service coverage and 14 manufacturing facilities in Brazil, China, Europe and India.

For more information on Hyva, please visit www.hyva.com

or follow us on:



Hyva Holding B.V.
Antonie van Leeuwenhoekweg 37
2408 AK Alphen aan den Rijn
The Netherlands
Telephone: +31 (0)172 - 42 35 55
Telefax: +31 (0)172 - 42 08 80
info@hyva.com
www.hyva.com



**Quality and
environmental certified**

DEALER STAMP